



# DURA-FLO INVERTED BUCKET STEAM TRAPS

Pressures To 250 PSIG (17.2 barg)  
Temperatures to 450°F (232°C)

**Hardened Stainless Steel Valve and Seat** — Long life and maximum corrosion resistance.

**Stainless Steel Bucket** — Long lasting, rugged and naturally resistant to water hammer.

**Inexpensive** — Low maintenance and initial cost.

**Repairable in-line** — All working parts lift out of top of trap.

**Cast Iron Body** — Durable heavy wall construction provides years of reliable service.

**Suitable for Wide Variety of Loads/Applications** — Horizontal and vertical models in thirteen body sizes.

**Resists Dirt and Scale** — Valve and seats positioned at top of traps and internal stainless strainer available on most horizontal models ensure long service.

## APPLICATIONS

- Steam Lines
- Process Equipment
- Steam Cookers
- Steam Heated Vats
- Pressing Machinery
- Unit Heaters
- Oil Preheaters
- Converters
- Coils
- Rotating Drum

## OPTIONS *See page 9*

- Repair Kits

Canadian Registration # OE 0591.1C

*Installation Tip:* Always install STV Test & Block Valve as part of trap station SEE PAGE 120

*Installation Tip:* Add Uniflex Pipe Coupling for ease of maintenance SEE PAGE 102

## MODELS

- 80S—Low capacity horizontal w/integral strainer
- 81S—Medium low capacity horizontal w/integral strainer
- 82S—Medium capacity horizontal w/integral strainer
- 83S—Medium high capacity horizontal w/integral strainer
- 84—High capacity horizontal
- 85—Super high capacity horizontal
- 86—Ultra high capacity horizontal
- 21—Medium low capacity vertical
- 22—Medium capacity vertical
- 23—Medium high capacity vertical
- 24—High capacity vertical
- 25—Super high capacity vertical
- 26—Ultra high capacity vertical

## OPERATION

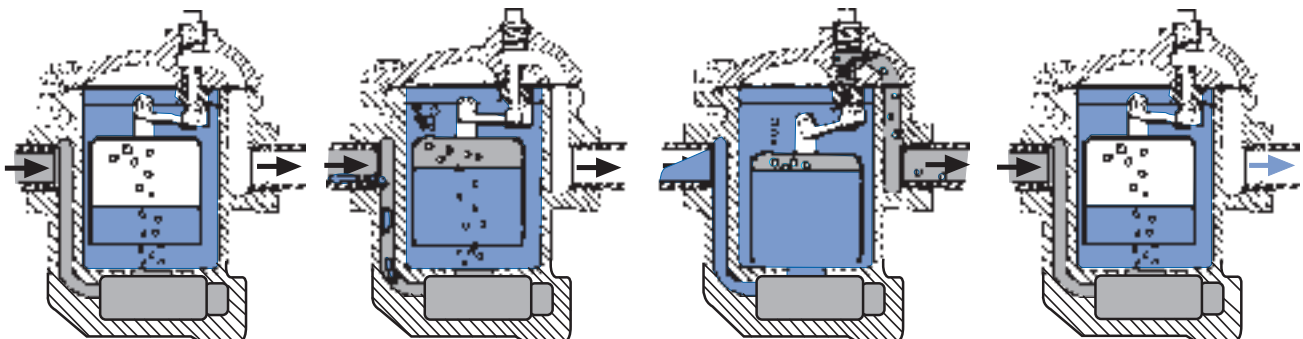

**Trap Closed** – After trap is installed and primed, steam entering the trap collects in the top of the bucket, floating the bucket and forcing the valve into its seat.

**Trap Begins to Open** – As condensate begins to flow into the trap, steam and air are forced from the bucket. This causes the bucket to begin losing buoyancy, tending to pull the valve from its seat.

**Trap Discharges** – When enough condensate has entered the trap, displacing the steam and air, the bucket drops, pulling the valve from the seat and allowing condensate and air to discharge.

**Trap Closes** – As the flow of condensate stops, steam enters the trap and refloats the bucket, forcing the valve into its seat. The cycle then repeats as more condensate reaches the trap.

# DURA-FLO INVERTED BUCKET STEAM TRAPS

## SPECIFICATION

Furnish and install as shown on the plans, inverted bucket traps capable of discharging condensate, air and other non-condensable gases without loss of steam. These traps shall have a heavy cast iron body, hardened stainless steel valve and seat, all stainless steel linkage and bucket, and an asbestos free fiber cover gasket.

### MAXIMUM OPERATING CONDITIONS

PMO: Max. Operating Pressure            see orifice selection  
 TMO: Max. Operating Temperature    saturated at pressure  
 PMA: Max. Allowable Pressure        250 psig (17.2 barg)  
 TMA: Max. Allowable Temperature    450°F (232°C)

### MATERIALS OF CONSTRUCTION

Body & Cover .....Cast Iron ASTM-A-126/A48  
 Bucket & Linkage .....Stainless Steel  
 Valve & Seat .....Hardened Chrome Steel  
 Standpipe .....Steel Pipe  
 Cover Gasket .....Asbestos Free Fiber

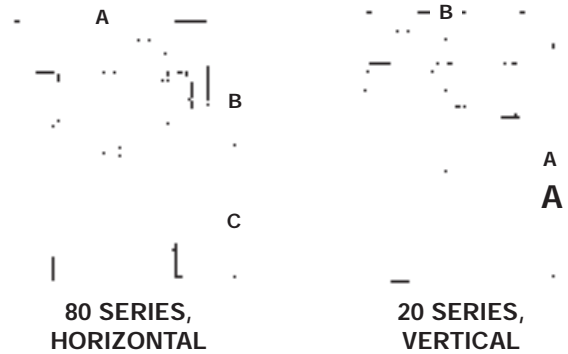

Connections: 1/2" - 2 1/2" NPT

DURA-FLO Dimension Table					
Trap	End Connections	Inches (mm)			Weight Lbs (kg)
		A	B	C	
80S	1/2, 3/4	5 1/6 (129)	2 1/6 (69)	3 1/2 (89)	7 (3.2)
81S	1/2, 3/4, 1	5 1/6 (129)	2 1/6 (69)	4 1/6 (113)	8 (3.6)
82S	1/2, 3/4	7 (178)	3 3/8 (98)	5 7/6 (138)	22 (10.0)
83S	3/4, 1	8 7/8 (206)	5 (127)	7 7/8 (194)	32 (14.5)
84	1, 1 1/4	9 (229)	5 3/4 (146)	7 1/6 (199)	47 (21.3)
85	1 1/2, 2	10 1/4 (260)	8 (203)	8 3/8 (213)	74 (33.6)
86	2, 2 1/2	13 (330)	9 3/4 (248)	11 (279)	140 (63.5)
21	1/2	6 3/8 (162)	4 1/4 (108)	—	6.5 (2.9)
22	1/2, 3/4	8 (203)	5 3/8 (143)	—	16 (7.3)
23	3/4, 1	10 1/2 (267)	6 7/8 (175)	—	28 (12.7)
24	1, 1 1/4	12 1/2 (318)	7 1/2 (190)	—	35 (15.9)
25	1, 1 1/2	14 3/8 (365)	9 1/6 (230)	—	60 (27.2)
26	1 1/2, 2	16 1/6 (424)	10 1/4 (260)	—	90 (40.8)

# DURA-FLO CAPACITY TABLES

Trap	Orifice		0.50 (.034)	1 (.069)	5 (.345)	10 (.690)	15 (1.03)	20 (1.38)	25 (1.72)	30 (2.07)	40 (2.76)	60 (4.14)	70 (4.83)	80 (5.52)	100 (6.90)	125 (8.62)	130 (8.97)	150 (10.3)	180 (12.4)	200 (13.8)	225 (15.5)	250 (17.2)
	Size	Max QP																				
80S	3/16	20	200	270	450	560	640	690														
	1/8	80	80	110	200	300	360	420	460	500	540	620	660	690								
	7/64	125	-	55	90	145	195	260	305	345	400	485	525	565	640	680						
	3/32	150	-	-	70	110	150	200	240	270	310	380	410	440	480	540	545	570				
81S & 21	1/4	15	300	450	830	950	1060															
	3/16	30	190	300	540	670	770	880	950	1000												
	5/32	70	100	165	180	430	495	585	655	710	770	900	950									
	1/8	125	70	130	220	340	390	460	515	560	610	710	760	800	860	950						
	7/64	200	-	65	150	230	275	335	375	405	455	545	580	610	665	735	780	810	850	860		
3/32	250	-	-	100	150	190	240	270	290	340	420	450	470	520	575	585	620	670	700	730	760	
82S & 22	5/16	15	570	850	1600	1900	2100															
	1/4	30	350	500	950	1380	1630	1800	1900	2050												
	3/16	70	250	420	785	950	1120	1260	1395	1500	1700	2000	2200									
	5/32	125	180	300	560	680	800	900	995	1070	1220	1440	1550	1650	1800	2000						
	1/8	200	100	180	325	465	505	575	650	710	805	980	1050	1105	1225	1375	1410	1500	1560	1600		
7/64	250	75	130	240	340	370	420	480	520	590	720	770	810	900	1010	1020	1100	1170	1230	1280	1300	
83S & 23	1/2	15	1410	1880	2900	3500	3900															
	3/8	30	990	1400	2300	2700	3300	3500	3800	4000												
	5/16	60	600	940	1730	2045	2510	2825	2995	3135	3800	4400										
	9/32	80	510	735	1350	1595	1960	2205	2340	2450	2880	3490	3800	4000								
	1/4	125	385	600	1100	1300	1600	1800	1910	2000	2350	2850	3100	3300	3600	3900						
	7/32	180	300	490	860	1165	1350	1595	1865	2085	2205	2510	2695	2820	3065	3185	3300	3500	3700			
3/16	250	255	400	700	950	1100	1300	1520	1700	1800	2050	2200	2300	2500	2600	2700	2800	3020	3200	3400	3500	
84 & 24	5/8	15	2160	2900	4800	5800	6500															
	1/2	30	1450	2250	3700	4750	5200	6000	6500	6800												
	3/8	60	1050	1750	2950	3550	4000	4700	5000	5400	5800	6800										
	11/32	80	800	1560	2500	2900	3200	3500	4000	4400	4850	5750	6000	6400								
	5/16	125	660	1200	1950	2450	2750	3100	3250	3500	4000	4800	5250	5600	6200	6700						
	9/32	180	550	950	1500	1900	2200	2350	2700	2900	3250	3800	4250	4500	4800	5500	5600	5700	6000			
1/4	250	350	580	1000	1250	1450	1800	2000	2200	2600	3150	3350	3500	3800	4300	4450	4700	5000	5300	5500	5700	
85 & 25	3/4	15	3100	4160	7600	9000	10000															
	9/16	30	1800	2900	5200	6400	7700	8500	9200	9800												
	7/16	60	1400	2200	3800	5000	6000	6600	7100	7600	8300	9500										
	3/8	100	1100	1700	3000	3600	4500	5200	5800	6100	7000	8500	9200	9700	10400							
	11/32	130	900	1500	2600	3200	3900	4500	5000	5400	6200	7500	8050	8500	9600	10900	11000					
	5/16	180	750	1200	2100	2600	3200	3700	4100	4500	5400	6600	7000	7257	8118	8979	9040.5	9500	10000			
	9/32	225	600	970	1700	2100	2600	2950	3300	3600	4500	5400	5700	5900	6600	7300	7350	7850	8400	9200	9800	
1/4	250	400	700	1200	1500	1900	2100	2400	2600	3200	3800	4000	4150	4600	5100	5150	5500	5950	6350	6650	7000	
86 & 26	1-1/16	15	6240	8400	14500	17300	19200															
	7/8	25	4100	5490	10000	12930	15620	18500	20000													
	3/4	40	2900	4500	8200	10600	12800	15000	16700	18000	20000											
	5/8	60	2100	3500	6900	8700	10600	12100	13300	14250	16300	19800										
	9/16	80	1900	3095	6000	7600	9300	10600	11700	12500	14300	17300	18300	19000								
	1/2	125	1600	2600	5000	6400	7800	8900	9800	10500	12000	14500	15400	16300	18000	20000						
	7/16	180	1400	2210	4180	5530	6640	7500	8490	9230	10450	12420	13300	14150	15750	17400	17900	18500	20000			
	3/8	250	1000	1800	3400	4500	5400	6100	6900	7500	8500	10100	10800	11500	12800	14200	14300	15600	16900	17500	18500	19000

For Kg/Hr Multiply by .454

# DURA-FLO INVERTED BUCKET STEAM TRAPS PCA REPAIR KITS

Quick, easy and economical  
Simplifies and standardizes inventory  
All stainless steel corrosion resistant internal parts  
Hardened stainless steel condensate valves and seats  
for extra long life

## MODELS

- 80S—Orifice ratings 20, 80, 125, 150
- 81S & 21—Orifice ratings 15, 30, 70, 125, 200, 250
- 82S & 22—Orifice ratings 15, 30, 70, 125, 200, 250
- 83S & 23—Orifice ratings 15, 30, 60, 80, 125, 180, 250
- 84 & 24—Orifice ratings 15, 30, 60, 80, 125, 180, 250
- 85 & 25—Orifice ratings 15, 30, 60, 100, 130, 180, 225, 250
- 86 & 26—Orifice ratings 15, 25, 40, 60, 80, 125, 180, 250

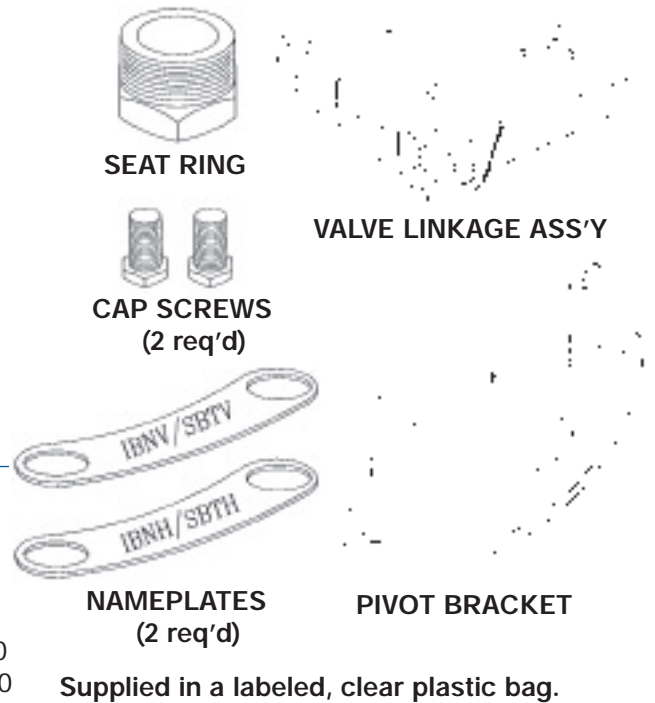

# FTN SERIES FLOAT & THERMOSTATIC STEAM TRAPS REPAIR KITS

High quality replacement kits  
Rebuild existing F & T Traps far more economically than  
replacement  
Quick, easy and economical  
Simplifies and standardizes inventory  
All stainless steel corrosion resistant internal parts  
Hardened stainless steel condensate valves and seats  
for extra long life  
Repairs other leading manufacturers' F & T Traps

## MODELS

- FTN-15 available in ¾", 1", 1¼", 1½" and 2"
- FTN-30 available in ¾", 1", 1¼", 1½" and 2"
- FTN-75 available in ¾", 1", 1¼", 1½" and 2"
- FTN-125 available in ¾", 1", 1¼", 1½" and 2"

All ¾" and 1" kits as well as 1¼" FTN-15 and FTN-30 kits  
supplied with cover assembly.

All 1¼" FTN-75 and FTN-125 kits as well as all 1½" and 2"  
kits supplied as mechanism complete.

See Capacity Charts on page 37

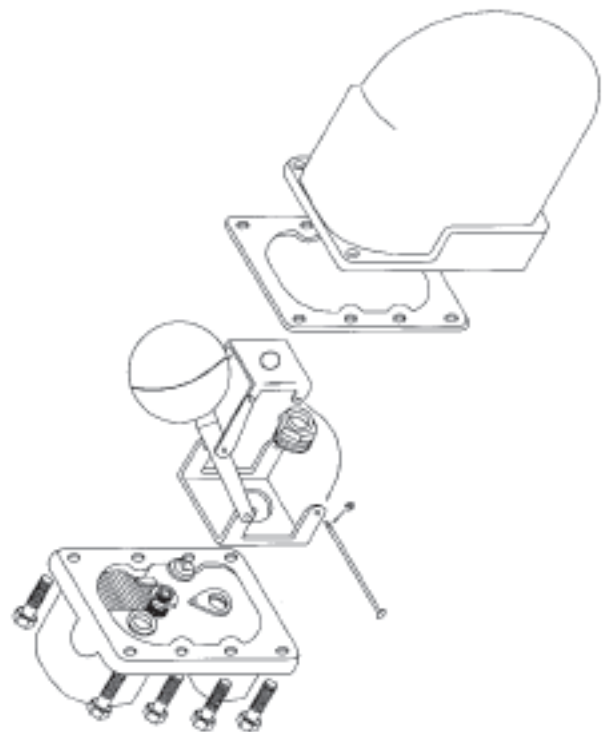

Consult factory for latest crossover fitments.



# SEALED STAINLESS STEEL DURA-FLO INVERTED BUCKET STEAM TRAPS

Pressures to 650 PSIG (45 barg)  
Temperatures to 497°F (258°C)

## APPLICATIONS

- Steam Lines
- Process Equipment
- Steam Cookers
- Steam Heated Vats
- Pressing Machinery
- Unit Heaters
- Oil Preheaters
- Converters
- Coils
- Rotating Drum

Canadian Registration #: OE10389.52

For information on Big Block UMTVS-BB Connector  
SEE PAGE 118

**Easy Trap Replacement** — Universal two bolt swivel mounting option simplifies removal from system.

**Simple Installation** — Stainless mounting Block mounts permanently into system. Trap installs via two bolt universal mount connection.

**Hardened Chrome Steel Valve and Seat** — Long life and maximum corrosion resistance.

**Stainless Steel Bucket** — Long lasting, rugged and naturally resistant to water hammer.

**Inexpensive** — Low maintenance and initial cost.

**Stainless Steel Body** — Durable heavy wall construction provides years of reliable service and resists corrosion and freezing.

**Suitable for Wide Variety of Loads/Applications** — Horizontal models in three body sizes.

**Resists Dirt and Scale** — Valve and seats positioned at top of traps ensure long service.

**Maintenance Free (TSBT-S and USBT-S)** — Sealed design prevents unnecessary tampering. Trap can be inspected and replaced without breaking pipe.

**Freeze Resistant** — Extruded SS Body helps prevent problems associated with freezing conditions.

## MODELS

### NPT CONNECTION

- **TSBT-LS** – Low Capacity, 200 PSIG
- **TSBT-MS** – Medium Capacity, 340 PSIG
- **TSBT-HS** – High Capacity, 650 PSIG

### UMT CONNECTION

- **USBT-LS** – Low Capacity, 200 PSIG
- **USBT-MS** – Medium Capacity, 340 PSIG
- **USBT-HS** – High Capacity, 650 PSIG

### UMT CONNECTOR BLOCKS

- **UMTC**–Standard connector (1/2" & 3/4" only)
- **UMTCY-RH**–Right Hand Connector with Y Strainer
- **UMTCY-LH**–Left Hand connector with Y Strainer
- **UMTVS-BB**–Connector with Isolation Valves, Strainer, Blowdown Valve and Test Port

## OPERATION

After trap is installed and primed, steam entering the trap collects in the top of the bucket, floating the bucket and forcing the valve into its seat. As condensate begins to flow into the trap, steam and air are forced from the bucket. This causes the bucket to begin losing buoyancy, tending to pull the valve from its seat. When

enough condensate has entered the trap, displacing the steam and air, the bucket drops, pulling the valve from the seat and allowing condensate and air to discharge. As the flow of condensate stops, steam enters the trap and re-floats the bucket, forcing the valve into its seat. The cycle then repeats as more condensate reaches the trap.

# SEALED STAINLESS STEEL DURA-FLO INVERTED BUCKET STEAM TRAPS

## SPECIFICATION

Furnish and install as shown on the plans, inverted bucket traps capable of discharging condensate, air and other non-condensable gases without loss of steam. These traps shall have a stainless steel sealed body, hardened chrome steel valve and seat and an all stainless steel linkage and bucket. It shall have a universal mount connector option.

## MAXIMUM OPERATING CONDITIONS

PMO: Max. Operating Pressure See Orifice Selection  
 TMO: Max. Operating Temperature Saturated at PMO  
 PMA: Max. Allowable Pressure -  
     LS 200 psig (13.8 barg) at 450°F (232°C)  
     MS 307 psig (21.2 barg) at 450°F (232°C)  
     HS 650 psig (44.8 barg) at 497°F (258°C)  
 TMA: Max. Allowable Temperature -  
     MS, LS & HS - 800°F (425°C)

## MATERIALS OF CONSTRUCTION

Body .....AISI 304 SS  
 Bucket .....AISI 304 SS  
 Bucket Clip .....AISI 304 SS  
 Lever .....AISI 304 SS  
 Inlet Tube.....AISI 304 SS  
 Valve .....Hardened Chrome Steel AISI D3  
 Valve Seat.....Hardened Chrome Steel AISI D3  
 Connector .....AISI 304 SS

## Maximum Capacity—(lbs/hr)

Trap	Orifice		Differential Pressure												
	Size	MOP	5 (0.34)	10 (0.69)	15 (1.03)	30 (2.07)	40 (2.76)	70 (4.83)	80 (5.52)	125 (8.62)	200 (13.79)	250 (17.24)	300 (20.69)	400 (27.59)	650 (44.83)
USBT-LS & TSBT-LS	3/32	200	85	120	145	200	230	300	325	400	500				
TSBT-MS	1/4	15	800	920	1040										
	3/16	30	540	690	800	1000									
USBT-MS & TSBT-MS	5/32	70	390	490	560	700	790	940							
	1/8	125	260	325	400	530	600	750	800	970					
	7/64	200	200	265	315	410	470	580	610	720	900				
	3/32	250	155	200	240	315	360	440	480	560	690	750			
TSBT-HS	5/64	400	100	130	155	210	235	280	310	360	440	460	510	580*	
	1/4	40	1040	1350	1580	2000	2350								
	3/16	80	680	930	1120	1550	1775	2400	2300						
	5/32	125	430	630	780	1050	1200	1700	1600	2000					
USBT-HS & TSBT-HS	1/8	250	320	420	510	700	790	1020	1090	1300	1650	1800			
	7/64	300	220	280	325	430	500	630	685	800	1000	1100	1200		
	3/32	650	175	225	270	370	400	510	540	650	800	870	930	1050	1300

For Kg/Hr Multiply by .454

\* CRN not available

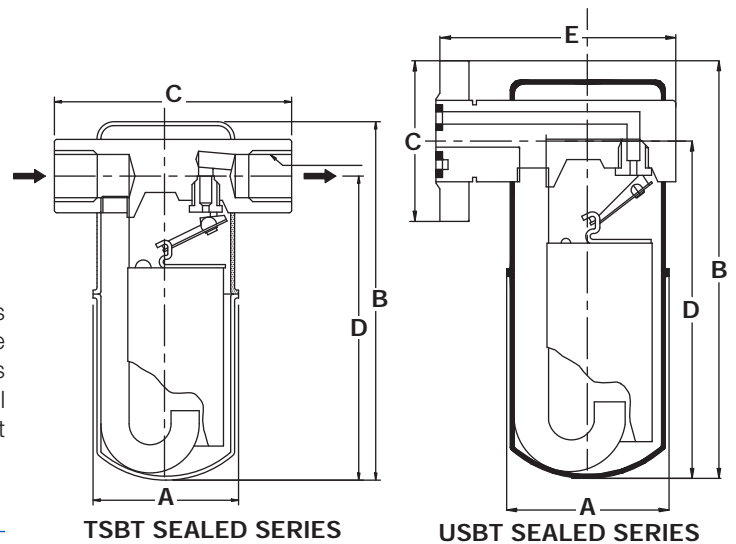

TSBT SEALED SERIES

USBT SEALED SERIES

Connections: 3/8" - 1" NPT

### DIMENSIONS inches (mm) AND WEIGHTS pounds (kg)

Model	Inches (mm)				Weight lbs(kg)
	A	B	C	D	
TSBT-LS	2 3/4 (70)	5 5/16 (142)	4 5/16 (110)	4 5/16 (116)	2.25 (1)
TSBT-MS	2 3/4 (70)	6 5/16 (167)	4 5/16 (110)	5 5/16 (141)	2.5 (1.1)
TSBT-HS	3 3/8 (99)	8 5/16 (218)	5 (127)	7 3/8 (187)	7 (3.2)

Connections:  
Universal Mount Two Bolt Swivel Connection

### DIMENSIONS inches (mm) AND WEIGHTS pounds (kg)

Model	Inches (mm)					Weight lbs(kg)
	A	B	C	D	E	
USBT-LS	2 3/4 (70)	6 (152)	2 3/4 (70)	4 3/8 (117)	4 (101.6)	4.25 (2)
USBT-MS	2 3/4 (70)	7 5/16 (183)	2 3/4 (70)	5 13/16 (148)	4 (101.6)	4.75 (2.2)
USBT-HS	3 3/8 (99)	8 3/8 (222)	2 3/4 (70)	7 3/8 (187)	5 (127)	7 (3.2)





# REPAIRABLE STAINLESS STEEL DURA-FLO INVERTED BUCKET STEAM TRAPS

Pressures to 650 PSIG (45 barg)  
Temperatures to 497°F (258°C)

## APPLICATIONS

- Steam Lines
- Process Equipment
- Steam Cookers
- Steam Heated Vats
- Pressing Machinery
- Unit Heaters
- Oil Preheaters
- Converters
- Coils
- Rotating Drum

Canadian Registration # OE10389.52

For information on Big Block UMTVS-BB Connector  
SEE PAGE 118

**Easy Trap Replacement** — Universal two bolt swivel mounting option simplifies removal from system.

**Simple Installation** — Stainless mounting Block mounts permanently into system. Trap installs via two bolt universal mount connection.

**Hardened Chrome Steel Valve and Seat** — Long life and maximum corrosion resistance.

**Stainless Steel Bucket** — Long lasting, rugged and naturally resistant to water hammer.

**Inexpensive** — Low maintenance and initial cost.

**Stainless Steel Body** — Durable heavy wall construction provides years of reliable service and resists corrosion and freezing.

**Suitable for Wide Variety of Loads/Applications** — Horizontal models in three body sizes.

**Resists Dirt and Scale** — Valve and seats positioned at top of traps ensure long service.

**Repairable Model (TSBT\_R & USBT\_R)** — Removable cover allows pressure change or repair with existing Dura-Flo PCA kits.

## MODELS

### NPT CONNECTION, REPAIRABLE

- TSBT-LR – Low Capacity, 200 PSIG
- TSBT-MR – Medium Capacity, 400 PSIG
- TSBT-HR – High Capacity, 650 PSIG

### UMT CONNECTION, REPAIRABLE

- USBT-LR – Low Capacity, 200 PSIG
- USBT-MR – Medium Capacity, 400 PSIG
- USBT-HR – High Capacity, 650 PSIG

### UMT CONNECTOR BLOCKS

- UMTC—Standard connector (1/2" & 3/4" only)
- UMTCY-RH—Right Hand Connector w/Y strainer\*
- UMTCY-LH—Left Hand Connector w/Y strainer\*
- UMTVS-BB—Connector with Isolation Valves, Strainer, Blowdown Valve and Test Port

## OPERATION

After trap is installed and primed, steam entering the trap collects in the top of the bucket, floating the bucket and forcing the valve into its seat. As condensate begins to flow into the trap, steam and air are forced from the bucket. This causes the bucket to begin losing buoyancy, tending to pull the valve from its seat. When enough condensate has

entered the trap, displacing the steam and air, the bucket drops, pulling the valve from the seat and allowing condensate and air to discharge. As the flow of condensate stops, steam enters the trap and re-floats the bucket, forcing the valve into its seat. The cycle then repeats as more condensate reaches the trap.

# REPAIRABLE STAINLESS STEEL DURA-FLO INVERTED BUCKET STEAM TRAPS

## SPECIFICATION

Furnish and install as shown on the plans, inverted bucket traps capable of discharging condensate, air and other non-condensable gases without loss of steam. These traps shall have a stainless steel sealed body, hardened chrome steel valve and seat and an all stainless steel linkage and bucket. It shall also have a universal mount connection option. The repairable traps shall have a removable cover to allow repair or orifice change.

## MAXIMUM OPERATING CONDITIONS

PMO: Max. Operating Pressure See Orifice Selection  
 TMO: Max. Operating Temperature Saturated at PMO  
 PMA: Max. Allowable Pressure -  
 LR 200 psig (13.8 barg) at 450°F (232°C)  
 MR 420 psig (29.0 barg) at 450°F (232°C)  
 HR 650 psig (44.8 barg) at 497°F (258°C)  
 TMA: Max. Allowable Temperature 800°F (425°C)

## MATERIALS OF CONSTRUCTION

Body .....ASTM A351 CF8  
 Cover .....ASTM A351 CF8  
 Bucket .....AISI 304 SS  
 Bucket Clip .....AISI 304 SS  
 Lever .....AISI 304 SS  
 Inlet Tube .....AISI 304 SS  
 Valve .....Hardened Chrome Steel AISI D3  
 Valve Seat .....Hardened Chrome Steel AISI D3  
 Swivel Connector .....AISI 304 SS  
 Cover Gasket .....Spiral Wound 304 SS with Grafoil

## Maximum Capacity—(lbs/hr)

Trap	Orifice		Differential Pressure													
			5	10	15	30	40	70	80	125	200	250	300	400	650	
	Size	MOP	(0.34)	(0.69)	(1.03)	(2.07)	(2.76)	(4.83)	(5.52)	(8.62)	(13.79)	(17.24)	(20.69)	(27.59)	(44.83)	
USBT-LR & TSBT-LR	3/32	200	85	120	145	200	230	300	325	400	500					
	1/4	15	800	920	1040											
TSBT-MR	3/16	30	540	690	800	1000										
	5/32	70	390	490	560	700	790	940								
USBT-MR & TSBT-MR	1/8	125	260	325	400	530	600	750	800	970						
	7/64	200	200	265	315	410	470	580	610	720	900					
	3/32	250	155	200	240	315	360	440	480	560	690	750				
	5/64	400	100	130	155	210	235	280	310	360	440	460	510	580*		
TSBT-HR	1/4	40	1040	1350	1580	2000	2350									
	3/16	80	680	930	1120	1550	1775	2400	2300							
	5/32	125	430	630	780	1050	1200	1700	1600	2000						
USBT-HR & TSBT-HR	1/8	250	320	420	510	700	790	1020	1090	1300	1650	1800				
	7/64	300	220	280	325	430	500	630	685	800	1000	1100	1200			
	3/32	650	175	225	270	370	400	510	540	650	800	870	930	1050	1300	

For Kg/Hr Multiply by .454

\* CRN not available

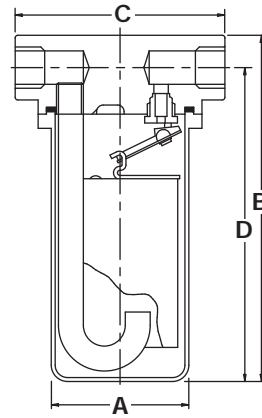

TSBT REPAIRABLE SERIES

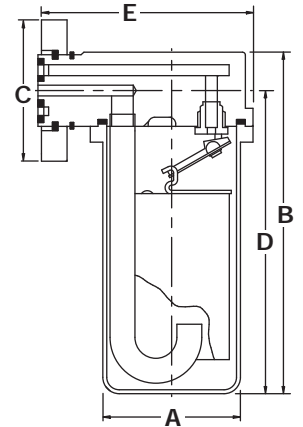

USBT REPAIRABLE SERIES

Connections: 3/8" - 1" NPT

DIMENSIONS inches (mm)  
AND WEIGHTS pounds (kg)

Model	Inches (mm)				Weight lbs(kg)
	A	B	C	D	
TSBT-LR	2 1/2 (73)	6 1/4 (159)	4 1/8 (110)	5 1/8 (141)	6.6 (3.0)
TSBT-MR	2 1/2 (73)	7 1/4 (184)	4 1/8 (110)	6 1/8 (166)	7.2 (3.2)
TSBT-HR	4 1/8 (104.8)	9 1/2 (241.3)	5 (127)	8 1/2 (215.9)	22 (10)

Connections:  
Universal Mount Two Bolt Swivel Connection

DIMENSIONS inches (mm) AND WEIGHTS pounds (kg)

Model	Inches (mm)					Weight lbs(kg)
	A	B	C	D	E	
USBT-LR	2 1/2 (73)	6 1/8 (161)	2 1/4 (70)	5 1/8 (143)	4 1/4 (108)	7.25 (3.3)
USBT-MR	2 1/2 (73)	7 1/8 (186)	2 1/4 (70)	6 1/8 (168)	4 1/4 (108)	8 (3.6)
USBT-HR	4 1/8 (104.8)	9 1/4 (247.7)	2 1/4 (70)	8 1/4 (222.3)	6 1/4 (158.8)	25 (11.33)